



CITY OF DETROIT
DEPARTMENT OF PUBLIC WORKS
CITY ENGINEERING DIVISION

COLEMAN A. YOUNG MUNICIPAL CENTER
2 WOODWARD AVE. SUITE 601
DETROIT, MICHIGAN 48226
PHONE: (313) 224-3949 • TTY: 711
FAX: (313) 224-3471
WWW.DETROITMI.GOV

March 12th, 2024

Honorable City Council:

RE: Petition No. x2024-081 – AT&T, request for encroachment within the public alley, lying adjacent to the parcels commonly known as 10604 & 10612 Somerset Avenue, for the installation of concrete pads, utility cabinets, and bollards.

Petition No. x2024-81 – AT&T, request for encroachment within the public alley, 18 ft. wide, lying adjacent to the parcels commonly known as 10604 & 10612 Somerset Avenue, for the installation of concrete pads, utility cabinets, and bollards.

This petition comes as part of a communications utility improvement plan to service the community.

The petition was referred to the City Engineering Division – DPW for investigation and report. This is our report.

The request was approved by the Solid Waste Division – DPW, and City Engineering Division – DPW. Traffic Engineering Division

Detroit Water and Sewerage Department (DWSD) reports being involved, but they have no objection provided the DWSD encroachment provisions are followed. The DWSD provisions have been made a part of the resolution.

All other involved City Departments, including the Public Lighting Authority and Public Lighting Department; also privately owned utility companies have reported no objections to the encroachment. Provisions protecting all utility installations are part of the attached resolution.

I am recommending adoption of the attached resolution.

Respectfully submitted,

Richard Doherty, P.E., City Engineer
City Engineering Division – DPW

Cc: Ron Brundidge, Director, DPW
Mayor's Office – City Council Liaison

COUNCIL MEMBER _____

RESOLVED, that the Department of Public Works, City Engineering Division is hereby authorized and directed to issue permits to AT&T or their assigns to install and maintain encroachment within the public alley, further described as: Land in the City of Detroit, Wayne County, Michigan;

1. Utility Cabinet, within the public alley, 18 ft. wide, lying easterly of and adjacent to lot 141 of "Jacob Young's Houston Avenue Subdivision" as recorded in Liber 46, Page 95 of Plats, Wayne County Records. Said utility cabinet includes the construction of a 50"x52" polymer pad for the placement of a fiber cross connect cabinet measuring 47.38' long, 48.87' height, and 19.58' wide. Said cabinet will connect to the utility pole, located north of and adjacent to the cabinet placement, using a 1.25" HDPE pipe to transfer the conduit. Said HDPE pipe shall be buried below the frost line between the polymer pad and utility pole.
2. Utility Cabinet, within the public alley, 18 ft. wide, lying easterly of and adjacent to lot 140 of "Jacob Young's Houston Avenue Subdivision" as recorded in Liber 46, Page 95 of Plats, Wayne County Records. Said utility cabinet includes the construction of a 50"x52" polymer pad for the placement of a fiber cross connect cabinet measuring 47.38' long, 48.87' height, and 19.58' wide. Said cabinet will connect to the utility pole, located south of and adjacent to the cabinet placement, using a 1.25" HDPE pipe to transfer the conduit. Said HDPE pipe shall be buried below the frost line between the polymer pad and utility pole.
3. Utility Cabinet, within the public alley, 18 ft. wide, lying easterly of and adjacent to lot 140 of "Jacob Young's Houston Avenue Subdivision" as recorded in Liber 46, Page 95 of Plats, Wayne County Records. Said utility cabinet includes the construction of a 50"x52" polymer pad for the placement of a fiber cross connect cabinet measuring 47.38' long, 48.87' height, and 19.58' wide. Said cabinet will connect to the utility pole, located south of and adjacent to the cabinet placement, using a 1.25" HDPE pipe to transfer the conduit. Said HDPE pipe shall be buried below the frost line between the polymer pad and utility pole.

PROVIDED, that AT&T maintains the encroachment area for as long as the alley remains open for public access. Said maintenance includes keeping the cabinets, polymer pads, below grade pipes/conduits in good condition, and ensure the area is keep of overgrowth or debris, and be it further

PROVIDED, that AT&T relocates the described assets in the event that City Council approves a petition, supported by 2/3 or 66% of adjacent property owners, for the vacation of the alley, and be it further

PROVIDED, that if there is any cost for the removing and/or rerouting of any utility facilities, it shall be done at the expense of the petitioner and/or property owner; and be it further

PROVIDED, that access is maintained to all fire department connections, and be it further

PROVIDED, that by approval of this petition the Detroit Water and Sewerage Department (DWSD) does not waive any of its rights to its facilities located in the right-of-way, and at all times, DWSD, its agents or employees, shall have the right to enter upon the right-of-way to

maintain, repair, alter, service, inspect, or install its facilities. All costs incident to the damaging, dismantling, demolishing, removal and replacement of structures or other improvements herein permitted and incurred in gaining access to DWSD's facilities for maintenance, repairing, alteration, servicing or inspection caused by the encroachment shall be borne by the petitioner. All costs associated with gaining access to DWSD's facilities, which could normally be expected had the petitioner not encroached into the right-of-way, shall be borne by DWSD; and be it further

PROVIDED, that all construction performed under this petition shall not be commenced until after (5) days written notice to DWSD. Seventy-two (72) hours' notice shall also be provided in accordance with P.A. 53 1974, as amended, utilizing the MISS DIG one call system; and be it further

PROVIDED, that construction under this petition is subject to inspection and approval by DWSD forces. The cost of such inspection shall, at the discretion of DWSD, be borne by the petitioner; and be it further

PROVIDED, that if DWSD facilities located within the right-of-way shall break or be damaged as the result of any action on the part of the petitioner, then in such event the petitioner agrees to be liable for all costs incident to the repair, replacement or relocation of such broken or damaged DWSD facilities; and be it further

PROVIDED, that the petitioner shall hold DWSD harmless for any damages to the encroaching device constructed or installed under this petition which may be caused by the failure of DWSD's facilities; and be it further

PROVIDED, or their assigns shall apply to the Buildings and Safety Engineering Department for a building permit prior to any construction. Also, if it becomes necessary to open cut public streets, bore, jack, occupy or barricade city rights-of-way for maintenance of encroachments such work shall be according to detail permit application drawings submitted to the City Engineering Division – DPW prior to any public right-of-way construction; and further

PROVIDED, that the necessary permits shall be obtained from the City Engineering Division – DPW and the Buildings and Safety Engineering Department. The encroachments shall be constructed and maintained under their rules and regulations; and further

PROVIDED, that all cost for the construction, maintenance, permits and use of the encroachments shall be borne by AT&T or their assigns, and further

PROVIDED, that all costs incurred by privately owned utility companies and/or city departments to alter, adjust, and/or relocate their existing utility facilities located in close proximity to the encroachments shall be borne by AT&T or their assigns. Should damages to utilities occur AT&T or their assigns shall be liable for all incidental repair costs and waives all claims for damages to the encroaching installations; and further

PROVIDED, that no other rights in the public streets, alleys or other public place shall be considered waived by this permission which is granted expressly on the condition that said

encroachments shall be removed at any time when so directed by the City Council, and the public property affected shall be restored to a condition satisfactory to the City Engineering Division – DPW; and further

PROVIDED, that AT&T or their assigns shall file with the Department of Public Works – City Engineering Division an indemnity agreement in form approved by the Law Department. The agreement shall save and protect the City of Detroit from any and all claims, damages or expenses that may arise by reason of the issuance of the permits and the faithful or unfaithful performance of AT&T or their assigns of the terms thereof. Further, AT&T or their assigns shall agree to pay all claims, damages or expenses that may arise out of the use, repair and maintenance of the proposed encroachments; and further

PROVIDED, that construction of the encroachments shall constitute acceptance of the terms and conditions as set forth in this resolution; and be it further

PROVIDED, this resolution is revocable at the will, whim or caprice of the City Council, and AT&T acquires no implied or other privileges hereunder not expressly stated herein; and further

PROVIDED, that the encroachment permits shall not be assigned or transferred without the written approval of the City Council; and be it further

PROVIDED, that AT&T shall remove the assets described under this resolution in the event that DWSD requires the removal for sewer replacement or maintenance; and be it further

PROVIDED, that the City Clerk shall within 30 days record a certified copy of this resolution with the Wayne County Register of Deeds.

MAP-24-3

SOMERSET AVE. 60 FT. WD.

GRAYTON AVE. 60 FT. WD.

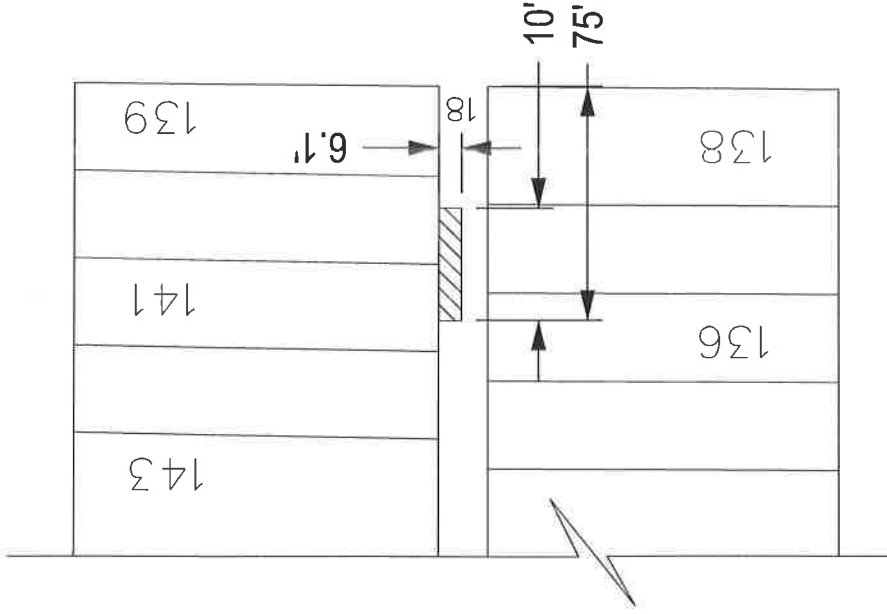

GRAYTON AVE. 60 FT. WD.

SOMERSET AVE. 60 FT. WD.

156	155	153	151	149	147	145	143	141	139	138	136	134	132	130	128	126	124	122	
35	35	35	35	35	35	35	35	35	35	45	35	35	35	35	35	35	35	35	45
46.55	141.60	141.50	141.50	141.50	141.50	141.50	141.50	141.50	141.50	141.50	141.50	141.50	141.50	141.50	141.50	141.50	141.50	141.50	141.50

BALFORD RD. 60 FT. WD.

YORKSHIRE RD. 60 FT. WD.

BALFORD RD. 60 FT. WD.

- REQUEST ENCROACHMENT

(FOR OFFICE USE ONLY)

CARTO - 97 E

B					
A					
DESCRIPTION		DRWN	CHKD	APPD	DATE
REVISIONS					
DRAWN BY	AP	CHECKED	LC		
DATE	01-24-2024	APPROVED	JD		

CITY OF DETROIT
 CITY ENGINEERING DIVISION
 SURVEY BUREAU
 JOB NO. 24-3
 DRWG. NO.

REQUEST ENCROACHMENT
 INTO SOUTH PUBLIC ALLEY, 18 FT. WD.
 AT 10604 SOMERSET AVE.



